

HAZARDOUS LOCATION GRP STROBE LIGHT Model WV450X

Hazardous Area Warning Light



WV450XD WV450XE

GLASS REINFORCED POLYESTER DESIGN FOR LOW MAINTENANCE AND CORROSION RESISTANCE

- Available in 10, 15 and 21 Joule Units
- Seven available lens colors: Amber, Blue, Clear, Green, Magenta, Red and Yellow
- 316 stainless steel mounting bracket included
- Available voltages ($\pm 15\%$):
10J – 110VAC and 220VAC only
15J – 24-48VDC only
21J – 110VAC and 220VAC only
- IP66
- Corrosion resistant GRP (Glass Reinforced Polyester)
- Included dome guard
- M20 entries standard
- Strobe tube life of 10,000 hours
- Body color natural black as standard - other colors available
- Zone rated, IECEx, ATEX
Ex d IIB +H2 T3-T4
Ex de IIB +H2 T3-T4

The Federal Signal model WV450X is ideally suited for explosive atmospheres and harsh environments. It is designed to serve the demanding needs of offshore marine and land based industrial applications. The housing is made of corrosion resistant components, which dramatically reduces the cost of long-term maintenance.

The WV450X utilizes all of the latest techniques in non-metallic housing construction. The body of the product is comprised of Glass Reinforced Polyester (GRP) and 316 stainless steel hardware. The use of GRP in the design improves corrosion resistance and reduces weight as compared to traditional metal housings. The GRP construction also saves time and money over the life of the product by reducing or, in most cases, completely eliminating the need to perform regular field inspections of the flame path.

The WV series comes standard with metric entries, a 316 stainless steel dome guard and a 10,000 hour rated strobe tube. There are two versions of the WV450X available with three Joule options each (10J, 15J and 21J). The flameproof "d" versions come standard with a 316 stainless steel mounting brackets and two M20 entries for field cable gland connections. The increased safety "e" versions have the added feature of a terminal chamber with three M20 entries. The increased safety design allows for quick field termination and pass through wiring.



Model	Operating Voltage	Maximum Operating Current	Joule Units	Temperature Code at 55°C	Flash Rate	Lamp Life Hrs.
WV450	110VAC	0.27 A	10	T3	60	10,000
	220-248VAC	0.23 A	10	T3	60	10,000
	24-48VDC	0.94/0.48 A	15	T4	60	10,000
	110VAC	0.75A	21	T3	60	10,000
	220-248VAC	0.50A	21	T3	60	10,000

tel: UK +44-(0)1625-666600 • USA +1-877-289-3246
www.fs-isys.com

FEDERAL SIGNAL
Safety and Security Systems / Industrial
Advancing security and well being.

SPECIFICATIONS

	Effective Candela Peak	Average Effective Candela on HV	Peak Intensity Candela	Actual Output Joules
10 Joules	174	110	195,000	10.75
15 Joules	312	195	298,000	16.3
21 Joules	393	297	357,700	21.5
Glass Color Transmission				
Red	Amber	Yellow	Blue	Green
<.81	<.48	<.85	<.12	<.52

Terminals: Ex d: (DC) 4 way block (2 in, 2 out)
(AC) 6 way block (3 in, 3 out)
Ex de: 3 position dual pole terminal block

Cable Entries: Ex d: 2 entries - M20 x 1.5
Ex de: 3 entries - M20 x 1.5

Operating Temperatures:
"d" version without terminal chamber
ATEX -55°C to 55°C (-67°F to 131°F)
IECEX -20°C to 55°C (-4°F to 131°F)

"e" version with terminal chamber
ATEX -20°C to 55°C (-40°F to 131°F)
IECEX -20°C to 55°C (-4°F to 131°F)

Mounting: Via 316 stainless steel bracket
Exterior Dome: Toughened glass
Guard: 316 Stainless steel
External Fasteners: 316 Stainless steel

Net/Shipping Weight:
WV450XD
Net 3.23 Kg (7.1 lbs.)
Shipping 3.88 Kg (8.6 lbs.)
WV450XE
Net 3.9 Kg (8.6 lbs.)
Shipping 4.54 Kg (10 lbs.)
Shipping Dimensions: 19 x 22 x 47 cm (7.5 x 9 x 18.5 in.)

ATEX Certificate Number DEMKO 06 ATEX 0425693X
Note: Covers 10,15, and 21 Joules

IECEX Certificate Number IECEX UL 06.0010X
Note: Covers 10, and 15 Joules only

Certification Marking ("d" only version) Ex d IIB + H2 T3-T4 @
-55°C ≤ Tamb ≤ 55°C

Certification Marking ("de" version) Ex de IIB + H2 T3-T4 @
-20°C ≤ Tamb ≤ 55°C

Ingress Protection (IP) Rating IP66

WV450XD

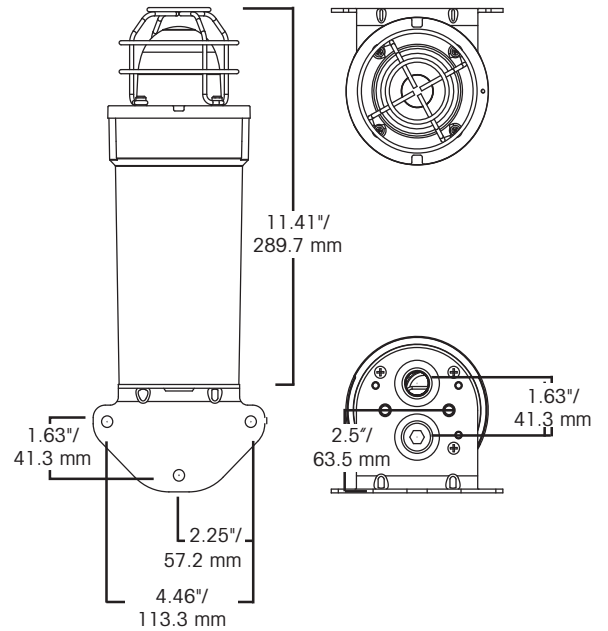

WV450XE

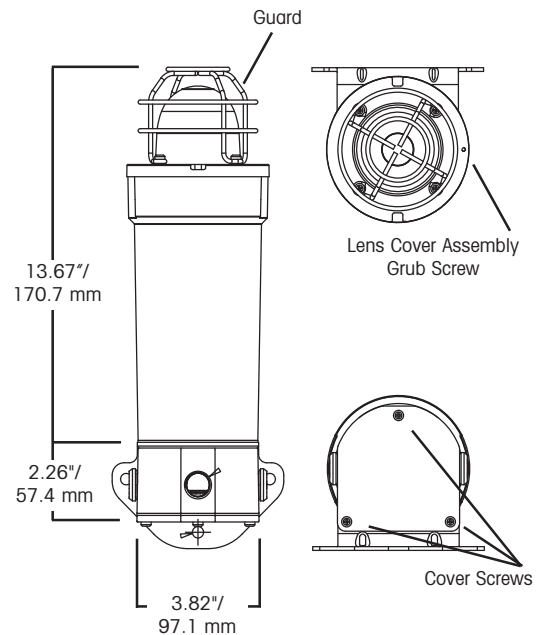

ORDERING CHART

WV450X		D	21	220	R	00	COLORS		SPECIAL FEATURES	
TYPE							Amber	A	00	None
PROTECTION							Blue	B	--	Retrofit Plate
Flameproof "d"		D					Clear	C	--	Body Colour
Increased Safety							Green	G		
"e" terminal box		E					Magenta	M		
RATING							Red	R		
10 Joule			10				Yellow	Y		
15 Joule			15							
21 Joule			21							
VOLTAGES ±15%										
10J - 110VAC and 220VAC only				110						
15J - 24-48VDC only				024						
21J - 110VAC and 220VAC only				220						

UK - Federal Signal Corporation, Integrated Systems
Hulley Road, Macclesfield, Cheshire SK10 2NF, UK
tel: +44 (0)1625 66 66 00 fax: +44 (0) 1625 611 352
web: www.fs-isys.com email: systems@fedsig.co.uk

USA - Federal Signal Corporation, Integrated Systems
2645 Federal Signal Drive, University Park, IL 60466, USA
tel: +1 708-534-4723 fax: +1 708-534-4887
web: www.fs-isys.com email: systems@fedsig.com