

MODEL SELECTFONE®

INSTRUCTION SHEET FOR FEDERAL
SELECTFONE

Address all communications and shipments to:



FEDERAL SIGNAL CORPORATION

Electrical Products Division

Service Department

2645 Federal Signal Drive

University Park, IL 60466-3195

INSTRUCTION SHEET FOR FEDERAL SELECTFONE® INTERCOM/PAGING SYSTEM

SAFETY NOTICES

WARNING

Failure to follow all safety precautions and instructions may result in property damage, serious injury, or death to you or others.

SAFETY MESSAGE TO INSTALLERS, USERS, AND MAINTENANCE PERSONNEL

I. GENERAL

The **SelectFone®** intercom and paging systems are designed for voice communication for industrial environments where the communication equipment is installed in high-noise areas, corrosive atmospheres, hazardous areas, and extremes of temperature, dust, and humidity. The intercom system allows the operator to both page instructions over the 15-Watt, 8-Ohm speakers and have two-way conversations between two or more people on a telephone party line. With a five-channel intercom system multiple communication links can be established simultaneously without cross talk or interference.

Ease of installation, simplified operation, simplified maintenance, unrestricted expansion, and unshielded cable are some of the benefits of the Federal Signal **SelectFone** intercom system.

Typical installations include power plants, metal processing plants, mining operations, petroleum and chemical plants, paper mills, water treatment facilities, and manufacturing, packaging, and processing plants.

A typical **SelectFone** intercom station features an impact resistant, Cyclocac® handset with noise canceling dynamic transmitter, and a receiver with a built-in push-to-page switch for one-hand operation. The front panel of each unit features a handset cradle equipped with a contact-less sensor to indicate an off-hook condition, an 'off-hook' indicator LED, and channel selector switch (on five-channel stations). In wall mount units, the 12-Watt paging amplifier, handset preamplifier, and power supply are enclosed in the housing. Desktop and panel mount units are equipped with the cables and connectors required to connect to the Remote Subset (within 10 feet), containing the paging amplifier, power supply, and handset amplifier. The amplifier and power supply assemblies features a plug-in design for ease of installation and service. Each unit is equipped with a terminal block for simplified installation.

II. SPECIFICATIONS

COMMON SPECIFICATIONS FOR ALL MODELS

Power Requirements

Operating voltage	105-130 VAC 50/60 Hz, 21 to 28 VDC (Nom. 24 VDC)
Standby Power Consumed	10 VA 120 VAC, 3 Watts 24VDC
Operating Power Consumed	33 VA 120 VAC, 28 Watts 24VDC max

Handset Amplifier

Output	1.5VRMS max. into 33 ohm load
Voltage Gain	68dB adjustable
Frequency Response	250-6500 Hz +/- 1.5dB
Distortion	2% THD max at 1000Hz
Controls	Microphone Gain, Receiver Volume

Speaker Amplifier

Output	12 Watts into 8 or 16 ohm load
Voltage Gain	31dB adjustable
Frequency Response	250-12000 Hz
Distortion	Less than 2% THD at 12 Watt, 1000Hz
Input Impedance	50k ohm
Output Impedance	8 ohm or 16 ohm
Controls	Speaker Volume Adjustable

Handset

Microphone	10 ohm dynamic noise canceling
Receiver	170 +/- 30 ohm high efficiency dynamic
Coil Cord	6 conductor, 10-ft extended

Agency Approvals

UL, cUL	Models SF-1011DT, SF-1015DT, SF-1011P & SF-1015P are listed for Class I, Div. 2 Grps. A, B, C & D. Models SF-1231X, SF-1235X, SF-1241X & SF-1245X are Listed for use in Class I, Div. 2; Class II Div 2 Groups F and G, and Class III Hazardous Locations
---------	---

BASIC MODEL SPECIFICATIONS

	Model SF-1011P	Model SF-1015P	Model SF-1011DT	Model SF-1015DT	Model SF-1231X	Model SF-1235X	Model SF-1241X	Model SF-1245X
Description	1 channel panel mount	5 channel panel mount	1 channel desktop	5 channel desktop	1 channel wall mount indoor	5 channel wall mount indoor	1 channel wall mount outdoor	5 channel wall mount outdoor
Dimensions subset HxWxD in.	9.5 x 7.86 x 4	9.5 x 7.86 x 4	9.5 x 7.86 x 4	9.5 x 7.86 x 4	N/A	N/A	N/A	N/A
Dimensions intercom HxWxD in.	3.75 x 6.5 x 6.0	3.75 x 6.5 x 6.0	9.25 x 4.0 x 9.0	9.25 x 4.0 x 9.0	9.5 x 7.86 x 7.7	9.5 x 7.86 x 7.7	16.0 x 13.06 x 8.5	16.0 x 13.06 x 8.5
Weight	16 lbs.	16 lbs.	16 lbs.	16 lbs.	10 lbs.	10 lbs.	19.0 lbs.	19.2 lbs.

III. INSTALLATION

SAFETY MESSAGE TO INSTALLERS

It is important to follow all instructions shipped with this product. This device is to be installed by a trained electrician who is thoroughly familiar with the National Electrical Code and will follow the NEC Guidelines as well as local codes.

The selection of the mounting location for the device, its controls, and the routing of the wiring is to be accomplished under the direction of the facilities engineer and the safety engineer. In addition, listed below are some other important safety instructions and precautions you should follow:

- Read and understand all instructions before installing or operating this equipment.
- Disconnect power before connecting or doing any maintenance on this intercom.

- All effective paging speakers produce loud sounds which may cause, in certain situations, permanent hearing loss. You should take appropriate precautions such as wearing hearing protection.
- After installation, ensure that all set screws are properly tightened.
- After installation, test the intercom to ensure that it is operating properly.
- After testing is complete, provide a copy of this instruction sheet to all operating personnel.
- Establish a procedure to routinely check the light installation for integrity and proper operation.

Failure to follow all safety precautions and instructions may result in property damage, serious injury, or death to you or others.

A. Unpacking

After unpacking the unit, examine it for damage that may have occurred in transit. If the equipment has been damaged, do not attempt to install or operate it, file a claim immediately with the carrier stating the extent of the damage. Carefully check all envelopes, shipping labels and tags before removing or destroying them.

B. Installation Of Subset, Wall Station and Indoor/Outdoor Station Enclosure

(See Figure 1, 2)

The remote subset unit for panel mount and desktop stations, the wall mount, and the indoor/outdoor wall mount SelectFone stations use the same enclosure to house motherboard, plug-in speaker amplifier, power supply etc. Only the front enclosure covers are different. The enclosures are designed to be mounted on a flat surface with user-supplied hardware. As the locations of SelectFone stations vary with each installation, these enclosures are not provided with conduit or cable openings. To install the SelectFone station enclosure, proceed as follows:

When the wall station is to be used in wet locations which require the use of the indoor/outdoor station enclosure which is rated Type 4X, Type 12, Type 13 and IP66, an equivalently rated cable gland or conduit hub must be used when connecting to the indoor/outdoor station enclosure.

1. Plan all the wiring and cable routing with the following guidelines in mind. While the distance between stations is not critical, the total power cable length should not exceed 5280 feet (1 mile) for 120VAC systems. The SelectFone system cable can be installed in cable trays or conduit. The maximum outside diameter of the five channel system cable is 0.65" (16.51 mm) and that of a single channel system is 0.43" (11 mm). Select the proper conduit size and make no more than two bends for each length as the excessive force required to pull the cable through may damage the insulation.
2. Determine the mounting location. The suggested mounting height for a wall station enclosure is 54" (137cm) up to the centerline of the enclosure. Ensure that the mounting surface is flat.
3. Remove the cover of the remote subset or wall mount SelectFone intercom station by removing four screws. Loosen the two screws and unplug the ribbon cable connector at CN1. This cable makes the connection between the handset amplifier board and the motherboard. Set the cover and screws aside.
4. The stations are shipped with the motherboard, power supply, and speaker amplifier installed as shown in the Figure 1. The best location for conduit or cable holes is the left half of the top or bottom wall or the left wall of the enclosure 1-3/4" from the bottom. Do not use the right half of the top wall and right wall to avoid interference with the power supply and speaker amplifier. Loosen the two screws that anchor the power supply to the standoffs on the bottom of the enclosure, unplug, and lift out. Similarly remove the speaker amplifier. Loosen the four screws at the four corners that anchor the motherboard to the standoffs mounted on the bottom of the enclosure and remove. Save all the hardware to reassemble the unit. Drill or punch the necessary conduit or cable openings in the empty enclosure.

5. Place the rear of the housing against the mounting surface. Using the four mounting holes located in each corner of the enclosure as a template, scribe mounting hole locations on the mounting surface.

CAUTION

To avoid damage when drilling, ensure that both sides of the mounting surface are clear of any parts or wires. Drill the holes only through the desired surface.

6. Drill four holes at the scribed mounting hole locations. Remove all burrs and sharp edges. Secure the housing to the surface with user-supplied hardware.
7. Attach the conduit to the enclosure. Feed the wiring through the conduit and bring it into the enclosure.
8. Re-install and secure the motherboard to the bottom of the enclosure with the four screws removed in Step #4. Wire the unit as described in Section E.
9. After completing the wiring, reinstall the speaker amplifier and power supply modules into the receptacles mounted on the motherboard and secure with the screws removed in Step 4. Plug-in the handset amplifier connector cable at CN1 and secure with the two screws. Re-install the enclosure cover and secure with the four screws removed in Step 3.

C. Panel Mount SelectFone Station Installation

The panel or flush mount intercom station consists of a panel mount handset unit and a remotely mounted subset unit. The subset unit consists of a handset amplifier, speaker amplifier, and power supply in an enclosure.

The panel mount handset assembly incorporates a black, impact resistant, Cyclocac®handset with noise canceling dynamic microphone, black cradle with proximity sensor hook switch, and a channel selector switch. It has a push-to-page switch located in the handset handle, an “off hook” indicator LED, and a 10 ft cable with 25-pin D subminiature connector. To install the panel mount unit follow the steps described below:

1. Install the subset enclosure within 10 ft of the panel or flush-mount unit as described in Section A and make electrical connections as described in the Section E.
2. Locate the handset assembly approximately 54" from the floor in an area where the wires and cable are free from interference. Ensure that the back of the panel is closed.
3. Using the template (see Figure 3) provided with the panel-mount handset assembly, make a rectangular cutout in the panel. Drill four holes in the panel to mount the handset assembly.
4. Pass the 25-pin D-subminiature connector through the cutout in the panel and anchor the handset assembly to the panel with user-supplied hardware.
5. Plug the 25-pin D-subminiature connector at the end of the cable to the 25-pin receptacle of the remotely mounted subset unit and fasten it with the two screws provided on the connector.

D. Desktop Station Installation

The SelectFone desktop station is similar in construction to the panel mount station. This station consists of a desk top handset assembly and a remote subset unit. The subset unit consists of the motherboard, the power supply module, the speaker amplifier, and the handset pre-amplifier board housed in an enclosure. The remote subset cover has a 25-pin D-subminiature receptacle to receive the connector from the desktop assembly.

The desktop unit incorporates an impact resistant, Cyclocac®handset with noise-canceling dynamic microphone and a channel selector switch. It has a push-to-page switch located in the

handset handle, an “off hook” indicator LED, a page receive speaker with volume control, and 10 ft cable with 25-pin D-subminiature connector. To install the desktop unit follow the steps described below:

1. Install the remote subset enclosure within 10 ft of the desktop handset unit as described in Section A and make electrical connections as described in the Section E. The suggested location for a remote subset with desktop unit is the knee-well of the desk.
2. Plug the 25-pin D-subminiature connector to the 25 pin receptacle of the remote subset and fasten it with the two screws provided.
3. Test the station for proper operation.

E. Electrical Connections (see Fig. 1, 4, 5)

WARNING

To avoid electrical shock, do not connect wires when power is applied.

The enclosure has a motherboard that provides designated screw terminal blocks for easy and trouble free connections of system cable. It allows sufficient space for the system cable to be looped in and out. The wires should be properly dressed and terminated inside the enclosure. The SelectFone stations are electrically paralleled. This allows system expansion by simply extending the system cable from the nearest SelectFone station.

Wire the station carefully by following the wire colors and using the spade lugs as shown in Figure 4. Perform all electrical wiring per the National Electrical Code.

a. 120 VAC Power Connection

All AC power wiring to the SelectFone station is made at the 3-position terminal block JP1 mounted on the motherboard. Connect the black (HOT) 14 AWG conductor of the incoming and outgoing cable to H terminal. Connect white (NEUTRAL) 14 AWG conductor to the terminal marked N. Connect the green/yellow (earth ground) 14 AWG conductor to the terminal marked GND.

A green 14 AWG ground conductor should be part of the system cable where no conduit or non-metallic conduit is used. If a non-metallic enclosure is used with metallic conduit and cable without ground conductor, there absolutely must be an electrical bond between conduit and terminal marked GND at terminal block JP1 of the SelectFone station.

WARNING

No SelectFone station should be installed or operated without having proper ground continuity.

b. 24VDC Power Connection for 24VDC SelectFone

The 24VDC SelectFone system stations are designed for operation from a 24VDC, rechargeable battery. A charger can be connected to maintain the batteries. Ground the negative side of battery only at one point for the system to reduce the hum and noise in the 24VDC SelectFone system.

WARNING

Do not operate 24VDC SelectFone system stations from a charger without a 24V battery connected to it because high, no load voltage (30V to 40V) of a 24V charger can damage the equipment. Never connect 24VDC SelectFone station to a supply voltage greater than 28VDC.

All SelectFone system stations are connected in parallel. 24VDC stations draw 1.5Amp. Max. current when page amplifier is driven by sine wave signal producing 12 watts in to an 8-ohm speaker. When planning 24VDC SelectFone system layout, careful consideration should be given to the power cable losses due to the voltage drop caused by cable resistance. To reduce the voltage drop in the long cable length it is recommended that several branches from 24VDC-power source be used to power the system and no more than six (6) stations should be connected to each power cable branch. An adequately rated fuse or a circuit breaker at the 24VDC source should be used to protect each power cable branch. For a 14 AWG power line this fuse or circuit breaker should be rated at 15Amp. The rating of the protection device is based on size of the power cable. Consult the National Electrical Code (NFPA 70) or Canadian Standards Association (CSA 22.1) for maximum allowable capacity of cable size used.

Note that cable distance between stations as well as total cable length must be considered. Table in this section will provide guideline for cable distance (length) and number of 24VDC stations connected to it in parallel. This table is based on speech signal driving station speaker/ amplifier to produce full 12watt output into an 8-ohm speaker. It is also assumed that stations are spaced at equal distance from one another along the cable length. A speech signal has less energy content than continuous sine wave signal so the average current draw per station is less than sine signal.

MAXIMUM CABLE DISTANCE PER POWERLINE BRANCH

NUMBER OF STATION	14AWG CABLE		12 AWG CABLE		10 AWG CABLE		8 AWG CABLE	
	TOTAL	BETWEEN STATIONS	TOTAL	BETWEEN STATIONS	TOTAL	BETWEEN STATIONS	TOTAL	BETWEEN STATIONS
1	4000ft	4000ft	6400ft	6400ft	10000ft	10000ft	16000ft	16000ft
2	2800ft	1400ft	4480ft	2240ft	7000ft	3500ft	11200ft	5600ft
3	2000ft	660ft	3200ft	1060ft	5000ft	1667ft	8000ft	2667ft
6	1200ft	200ft	1920ft	320ft	3000ft	500ft	4800ft	800ft
9	800ft	90ft	1280ft	142ft	2000ft	220ft	3200ft	356ft

The 24VDC power connections are made at the 3-position terminal block JP1 mounted on the motherboard in the station enclosure. Connect the black positive (+) 14 AWG conductor of incoming and out going power cable to the + terminal of JP1. Connect white, negative(-) 14 AWG conductor of incoming and out going power cable to the - terminal of JP1. Connect the green/yellow the earth ground 14 AWG conductor to the GND terminal of the JP1 terminal block.-

c. Page Line and Party Line Connection.

WARNING

To avoid electrical shock, do not connect wires when power is applied.

All the channel line and page line connections are made at the L1 and L2 terminal blocks mounted on the motherboard. The incoming and outgoing cable of multi-channel systems have six, differently colored, 18 AWG, twisted pair conductors. One conductor of each twisted pair is of solid color and the other has a stripe of the same color.

1. As shown in Figure 1, the page line connections are made to the **L1** and **L2** terminal blocks, at the terminals marked **L1** **PAGE** L2. Connect 18 AWG RED conductor of twisted pair RED, WHITE/RED of the incoming and outgoing cable to L1 and conductor WHITE/RED to L2 at location marked **PAGE** on the motherboard.

2. To make party line 1 connection, connect GREEN conductor of incoming and outgoing cable's 18 AWG twisted pair GREEN ,WHITE/ GREEN to L1 and WHITE/GREEN conductor to L2 terminal at location identified as **PARTY 1** between terminal blocks **L1** and **L2**.
3. For party line 2 connection, connect BROWN conductor of twisted pair BROWN, WHITE/BROWN to L1 and WHITE/BROWN conductor to L2 terminal at **PARTY 2**. For party line 3, connect ORANGE conductor of ORANGE, WHITE/ORANGE twisted pair to L1 and WHITE/ORANGE to L2 at **PARTY 3**. For party line 4, connect VIOLET conductor of twisted pair VIOLET, WHITE/VIOLET to L1 and WHITE/VIOLET to L2 at location **PARTY 4** and for party line 5, connect conductor GRAY to L1 and WHITE/GRAY to L2 terminals at **PARTY 5** location.

d. Paging Speaker Connection

As output to the speaker from the speaker amplifier of the SelectFone station is less than 11 volts RMS, the speaker wires falls into CLASS II of the NEC code and, hence, conduit is not required except for mechanical protection. To minimize power loss in the speaker cable, the length of the speaker cable should be as short as possible. The table in this section shows the wire size and corresponding maximum length of speaker cable allowed to maintain a cable power loss under 20% (1db).

As shown in the Figure 1, the connection to the 8 ohm or 16 ohm paging speaker is made at the terminal block marked JP2. Using 18 AWG twisted pair cable connect **-VE** terminal of the speaker to the terminal marked **C** at the terminal block **JP2** and connect **+VE** of the speaker terminal to the terminal marked **8** for 8 ohm impedance speaker or to the terminal marked **16** for 16 ohm impedance speaker.

It is recommended that when the Push-to-Page switch is pressed, the paging speaker connected to that station is silenced (muted) to prevent acoustic feedback to the handset microphone. This is why there is a jumper placed between terminals marked **IN** and **OUT** of the terminal block marked **JP2**. This does not prevent the speaker connected to the muted station from announcing the paging messages originated at other stations while channel line conversations are being carried out at the muted station.

Removing the jumper between **IN** and **OUT** terminals will disable the mute feature.

Wire Size	8 OHM output	16 OHM Output
#18 AWG	75 FEET(25 M)	150 FEET (50 M)
#16 AWG	120 FEET (35 M)	240 FEET (75 M)
#14 AWG	200 FEET (60 M)	400 FEET (120 M)

e. Line Balance Assembly Connection

One line balance assembly Model SF-1000LB must be installed with each SelectFone system. It should be located at the electrical center of the system. The line balance assembly properly loads the page line and all channel line circuits. Locate the line balance assembly unit within 12 inches of the SelectFone station located at the electrical center of the intercom system. See Fig. 6.

1. Remove the cover by loosening the four screws.
2. Place the rear of the housing against the mounting surface. Using the four mounting holes located in each corner of the enclosure as a template, scribe mounting hole locations on the mounting surface.

CAUTION

To avoid damage when drilling, ensure that both sides of the mounting surface are clear of any parts or wires. Drill the holes only through the desired surface.

3. The line balance assembly is supplied without conduit or cable entry holes. Drill or punch the necessary conduit or cable openings in the enclosure before mounting it to the surface. Remove all the metal shavings and debris from the enclosure.
4. Drill four holes at the scribed mounting hole locations. Remove all burrs and sharp edges. Secure the housing to the surface with the user-supplied hardware.
5. Attach the conduit to the enclosure. Feed the wiring through the conduit, and bring it into the enclosure.
6. Connect an 18AWG twisted pair wire between **SelectFone** station L1 PAGE L2 and Line Balance L1 PAGE-L2 terminals. Similarly connect the 18 AWG twisted pair wire for each channel line between terminals of LINE-BALANCE assembly and corresponding **SelectFone** station terminals as shown in Figures 1, 4, 5, and 6.

IV. ADJUSTMENTS AND OPERATION.

After all of the stations, the line balance assembly, and paging speakers have been installed and the wiring is complete, the system should be evaluated and adjustments made to ensure proper operation. Before beginning, verify that all station handsets are on hook.

Turn on AC power to the system and begin the evaluation at the SelectFone station closest to the line balance assembly. Lift the handset off hook; the off-hook indicator should turn on. Press the push-to-page switch on the handset and speak firmly and directly into the handset microphone, verifying that the message is audible over all speakers except those associated with that station. When paging, if the line balance assembly is connected properly and the page line is loaded properly, very little or no message should be heard on the handset receiver. If necessary, open the cover of the line balance assembly and adjust the page line loading by turning the control to the point where little or no page is audible in the handset receiver. In the future, if 10 or more units are added to the system, this adjustment may again be necessary.

After line balance adjustments are completed for the page line, the paging speaker volume level can be adjusted on the associated speaker/amplifier module. To access the speaker/amplifier volume level control, remove the station cover. The station is pre-set at the factory to produce 1/2 the maximum output level with moderate page line input.

Check the operation of all channels by holding a conversation between two or more **SelectFone** stations on each channel. If the line balance assembly is properly connected, the speaker should hear little or none of his own voice in the handset receiver. No channel line load adjustment is provided.

The handset transmitter signal is amplified by the handset/amplifier. The handset amplifier has a transmitter volume control and receiver level control. To access these controls remove the front cover of the station. These controls are located on the printed circuit board mounted to the back of the front cover and can be adjusted with a small screwdriver. These controls are pre-set at the factory to produce optimum results in the industrial environment. Before attempting to adjust these controls, check for a missing or improperly connected line balance assembly, crossed wires, or grounded wires. Stations located far (3000 feet or more) from the line balance assembly may require that the receiver level control be adjusted to compensate for cable resistance.

V. TROUBLESHOOTING

In an SelectFone system, AC power circuit conductors are in the same cable with communication conductors. Even if the system is properly installed, there is an AC voltage between page line or channel line conductors and ground. This is a result of the induced voltage that is due to the capacitance of

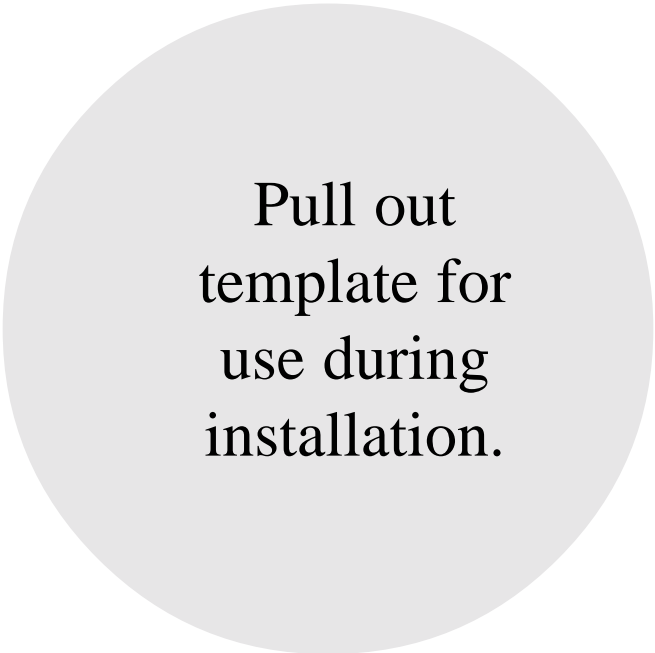

Pull out
template for
use during
installation.

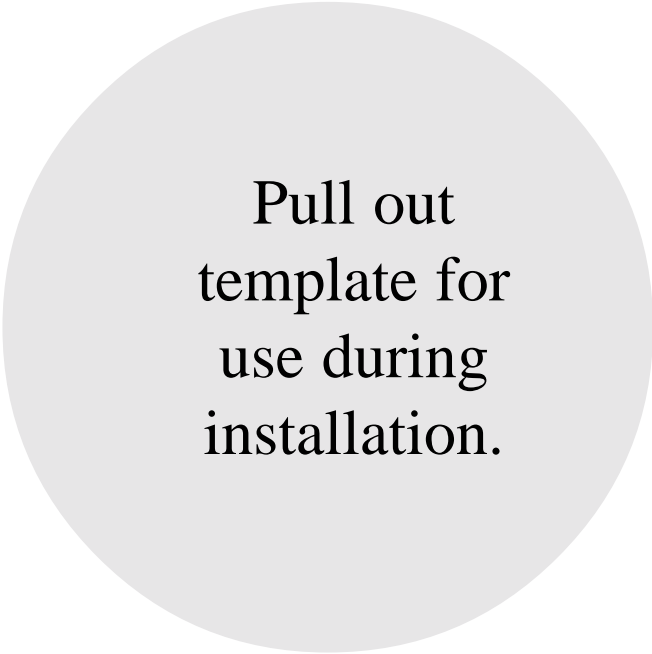

Pull out
template for
use during
installation.

the AC power circuit conductors running in parallel with the communication circuit conductors. At times this voltage can read 50 volts or more. This voltage is of no consequence because the page and channel lines are balanced twisted pair audio circuits.

In an SelectFone system, the audio voltage across page line conductors or across any channel line conductors (L1 and L2) is of the order of 0.5 to 0.75 volts peak when someone is speaking into the handset microphone. The voltage will be proportional to the person's voice speaking into the handset.

Hum or Buzz

When one of the two conductors in the page or channel lines short circuits to ground, the audio circuit becomes unbalanced. If there is leakage to ground from one of the conductors, the audio circuit becomes unbalanced.

When audio lines are balanced twisted pair, the induced noise voltage is the same on both conductors and, therefore, cancels out before it is amplified. But when the circuit becomes unbalanced, the induced noise voltage is not the same on both conductors and is, therefore, amplified and causes an audible hum or buzz. To solve the problem, locate the source of the ground by checking each conductor and moving from one junction point to the next and disconnecting the effected circuit. Improperly grounded circuits are often the result of poor terminations such that small strands protrude and touch adjacent terminals. In many instances, the presence of water or moisture and deposits in a junction box form a conductive solution that causes a ground fault or leakage to ground.

Low Level Audio At All Stations

This problem can occur when there is a dead short across any channel or page line. The system will still function but the audio level will be the lowest at the stations closest to the short. Locate the short by checking with an ohmmeter at the junction boxes and disconnecting the effected sections.

Cross Talk

Channel and page lines are twisted pair wires and balanced such that when circuits are accidentally crossed during installation interference between two lines will occur. Cross talk can also occur when there is leakage or a ground fault on two of the channel lines or when there is a missing or open line balance resistor. The resistance between the channel line circuits should be very high or infinite.

Inoperative Station

In a properly operating system an inoperative station indicates miswiring or a problem with the station itself. Check the wiring connection. If the problem is not caused by miswiring, swap the plug-in modules of the effected station with one that is operating properly to identify the defective module.

VI. MAINTENANCE.

SAFETY MESSAGE TO MAINTENANCE PERSONNEL

Listed below are some important safety instructions and precautions you should follow:

- Read and understand all instructions before installing or operating this system.
- Any maintenance to the SelectFone station must be done with power turned off.
- Any maintenance to the unit must be performed by a trained electrician in accordance with NEC Guidelines and local codes.
- Never alter the unit in any manner. Safety in hazardous locations may be endangered if additional openings or other alterations are made in units specifically designed for use in these locations.

- The nameplate, which may contain cautionary or other information of importance to maintenance personnel, should NOT be obscured in any way. Ensure that the nameplate remains readable when the housing's exterior is painted.

Failure to follow all safety precautions and instructions may result in property damage, serious injury, or death to you or others.

Other than cleaning, no regularly scheduled maintenance is required. To ensure unit is operating properly, it should be tested at regularly scheduled intervals.

VII. SERVICE

The Federal factory will service your equipment or provide technical assistance with any problems that cannot be handled locally.

Any units returned to Federal Signal for service, inspection, or repair must be accompanied by a Return Material Authorization. The R.M.A. can be obtained from the local Manufacturer's Representative or by calling the factory.

At this time a brief explanation of the service requested, or the nature of the malfunction, should be provided.

Address all communications and shipments to:

FEDERAL SIGNAL CORPORATION
 Electrical Products Division
 Service Department
 2645 Federal Signal Drive
 University Park, IL 60466-3195

VIII. SERVICE PARTS.

<u>Description</u>	<u>Part Number</u>
Power Supply Module	K2001883B
Power Supply Module 24VDC	K2001883B-01
Speaker/Amplifier Module	K2001882C
Speaker/Amplifier Module 24VDC	K2001897A
Handset Pre-amp PCBA	K2001881A
Handset Receiver Element	K8592034A
Main PCBA	K2001884A
Dynamic Microphone	K137147A
Main PCBA 24VDC	K2001884A-01
Receiver Cap, Black	K8592036A
Microphone Cap, Black	K8592037A
Page Push Button, Black	K8592038A
Cradle, Black	K8592029A
Handset Assembly, Black, Desktop	K8592082A
Handset Assembly, Black	K8592033A

1

SELECTFONE ENCLOSURE WITH COVER REMOVED (FIG. 1)

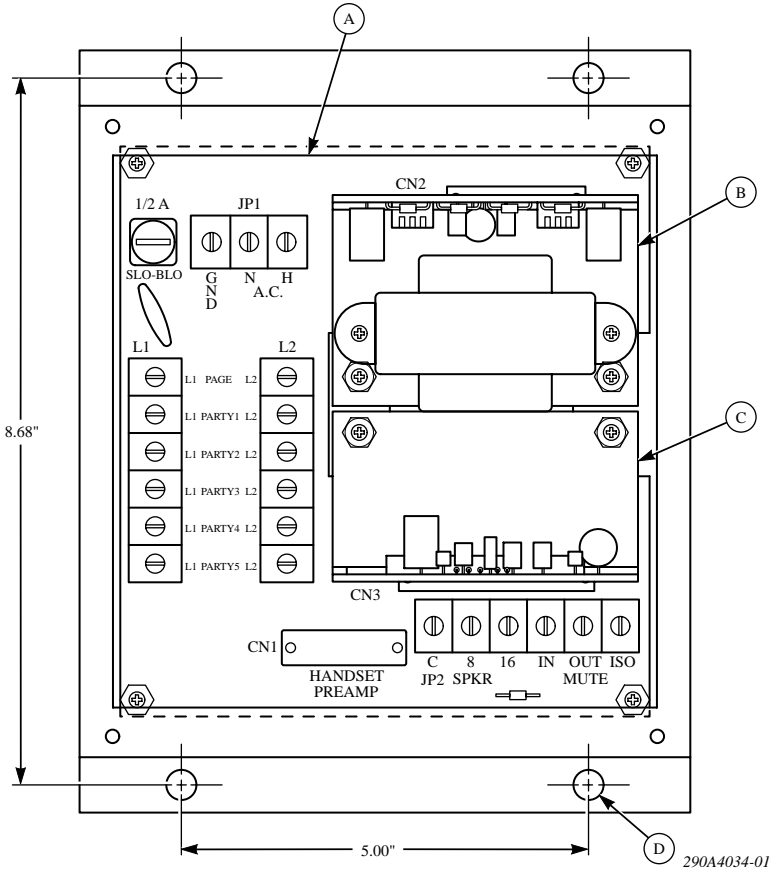

KEY

- A. Motherboard
- B. Power Supply Module
- C. Amplifier Module
- D. Enclosure Mounting Holes

2

**SELECTFONE INDOOR/OUTDOOR STATION
MODEL SF-1245X & SF-1241X (FIG. 2)**

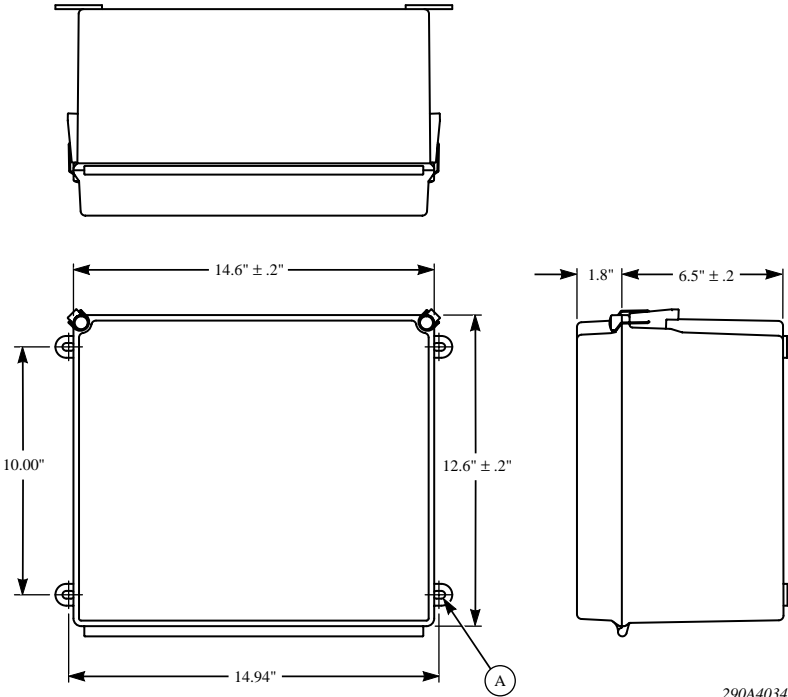

290A4034-02

KEY

A. Enclosure Mounting Holes

3

PANEL CUT-OUT TEMPLATE FOR SF-1015P & SF-1011P (FIG. 3)

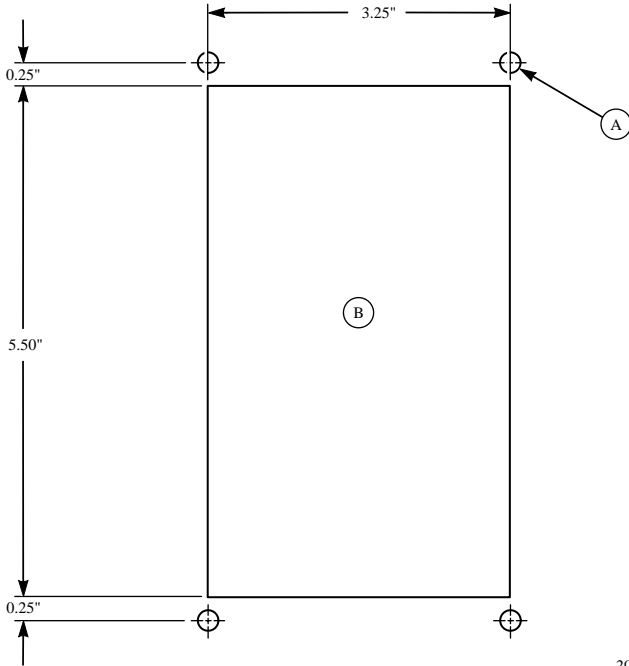

290A4034-03

KEY

- A. Mounting Holes
- B. Cut-Out

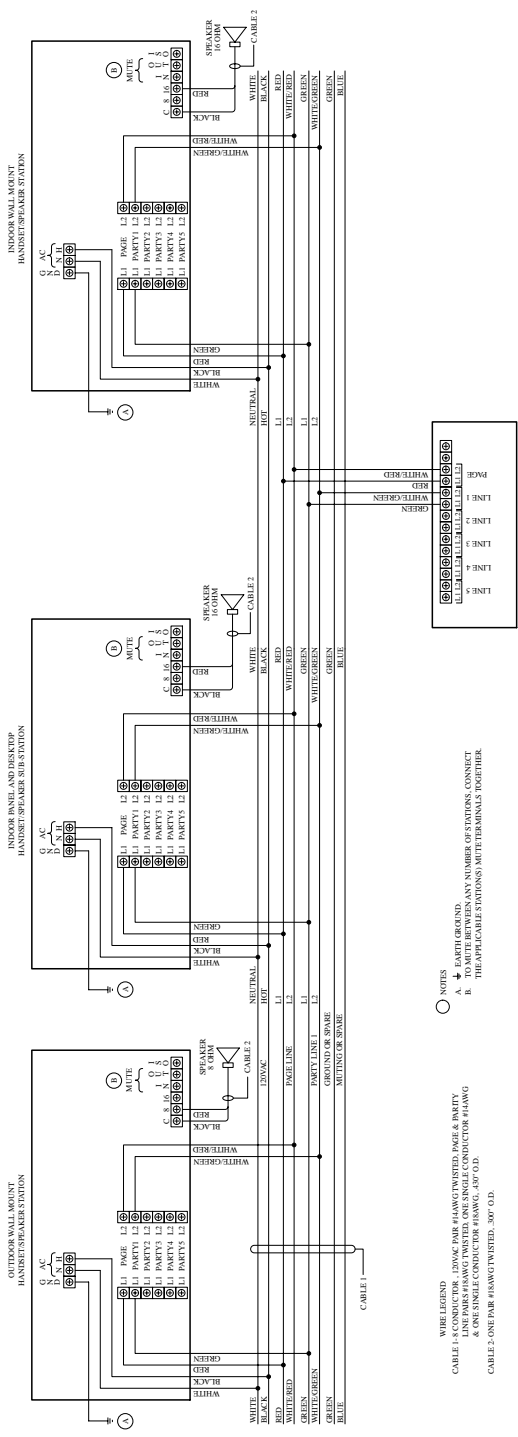

29044034-05

- NOTES
- A. ALL PARTS ARE GROUND.
 - B. TO MUTE BETWEEN ANY NUMBER OF STATIONS, CONNECT THE APPLICABLE STATIONS' MUTE TERMINALS TOGETHER.
- WIRE LEGEND
- CABLE 1 - ONE PAIR #18AWG PAIR #14AWG TWISTED PAIR 6 & 10 P. 1
 - LINE PAIR #18AWG TWISTED ONE SINGLE CONDUCTOR #18AWG & ONE SINGLE CONDUCTOR #18AWG .30" O.D.
 - CABLE 2 - ONE PAIR #18AWG TWISTED .30" O.D.

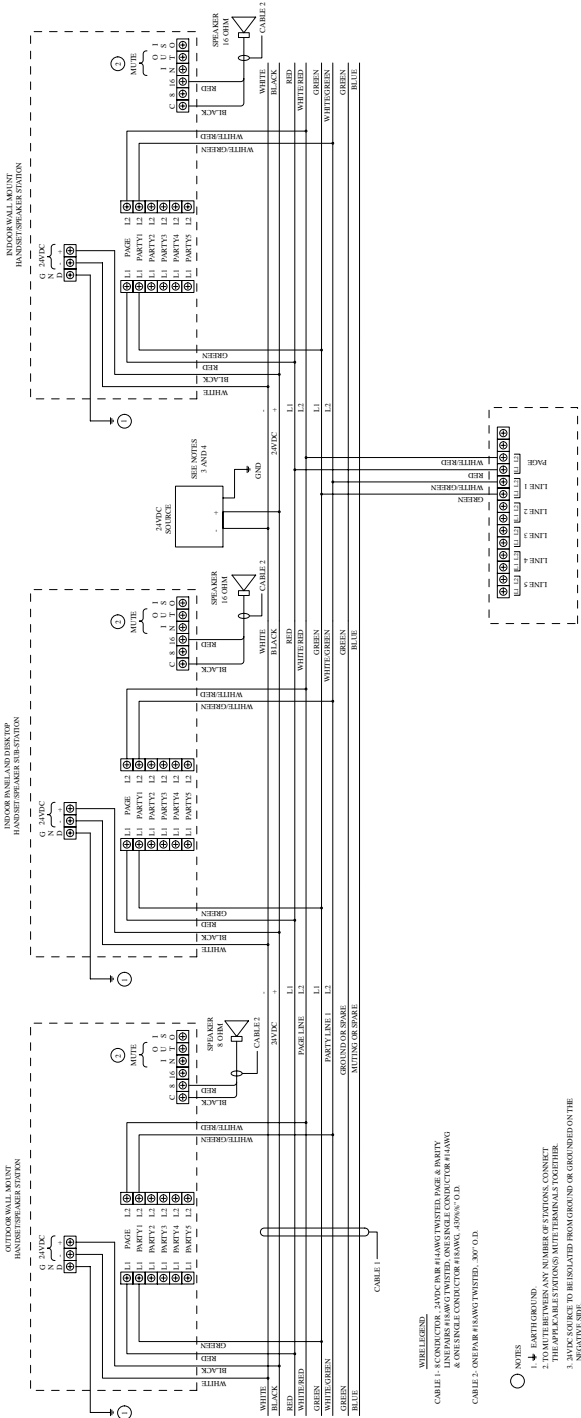

29044024-07

- WIRE LEGEND:
- CABLE 1 - 3 CONDUCTOR - 24VDC PER #14WG TWISTED PAIR & PARTY 1 TO PARTY 4
 - CABLE 2 - 3 CONDUCTOR - 24VDC PER #14WG TWISTED PAIR & ONE SINGLE CONDUCTOR #14WG, 490VAC, 0.0.0.
 - CABLE 2 - ONE PAIR #14WG TWISTED, .000" O.D.

- NOTES
1. EARTH GROUND.
 2. THE SPEAKER TERMINALS MUST BE TWISTED TOGETHER.
 3. 24VDC SOURCE TO BE ISOLATED FROM GROUND OR GROUND ON THE NEGATIVE SIDE.
 4. LOCAL DC SOURCE AS CLOSE TO CENTER OF SYSTEM AS POSSIBLE.

LINE BALANCE ASSEMBLY MODEL SF-1000LB (FIG. 6)

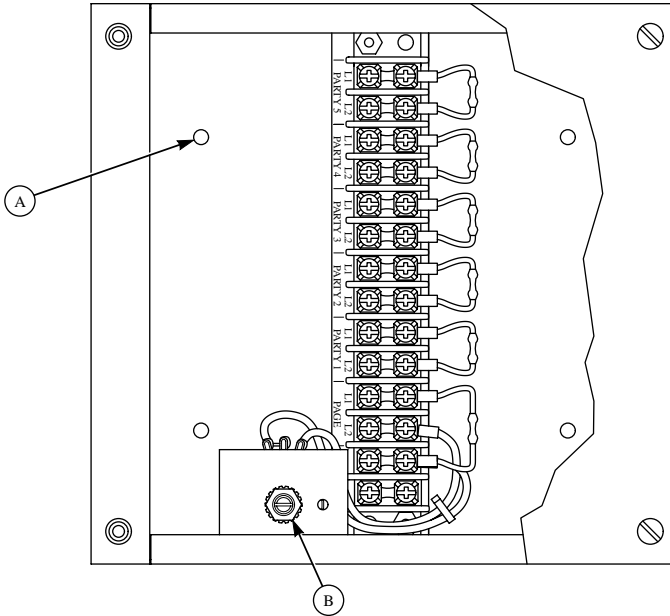

290A4034-08

KEY

- A. Mounting Holes
- B. Page Line Balance Adjustment